

BCA

escola  
britânica  
de artes  
criativas

AULA 3

# BRANDING & IDENTIDADE VISUAL

MÓDULO 7

# AGENDA

## ◆ tipos de grids

proporção aurea

simetria proposital

como construir seu grid

# tipos de grids

**Os grids podem  
aparecer de diversas  
formas e tamanhos.**



# TIPOS DE GRID

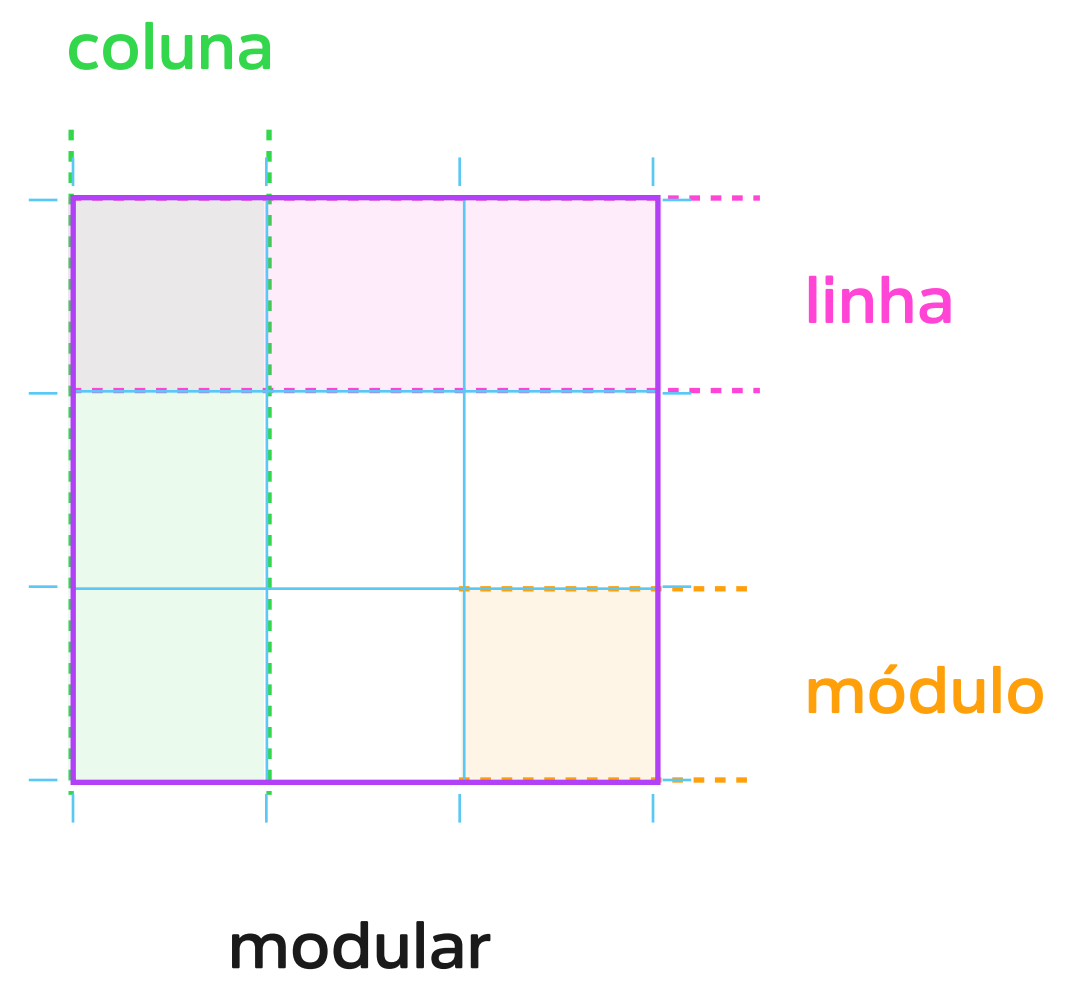

# TIPOS DE GRID

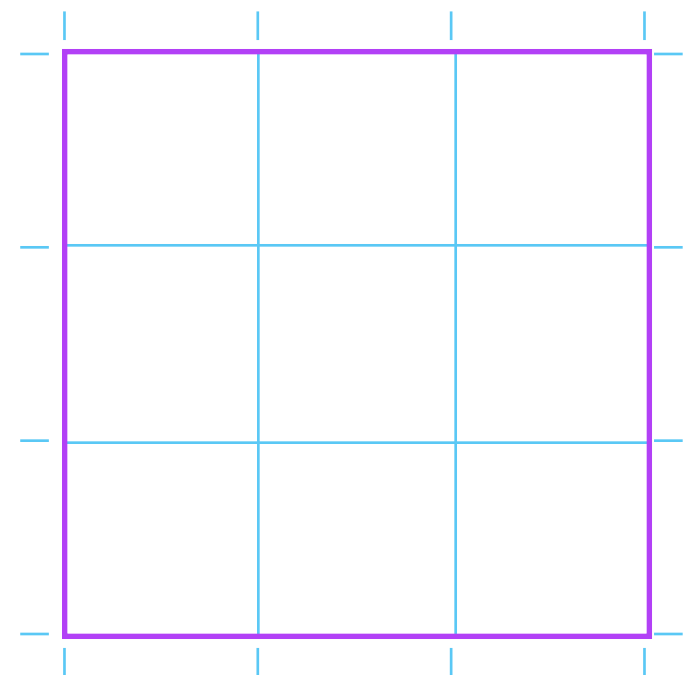

modular

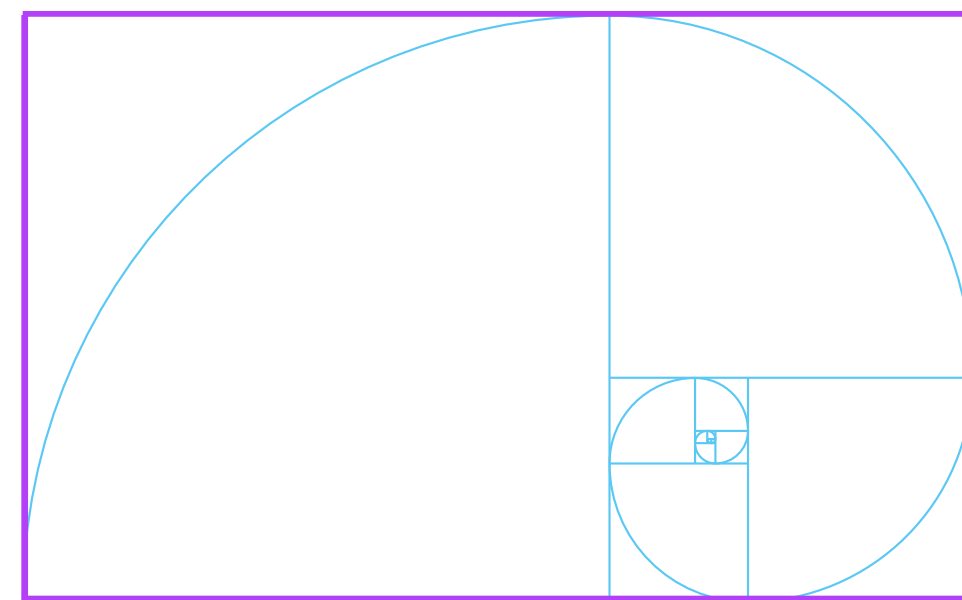

sequência de fibonacci

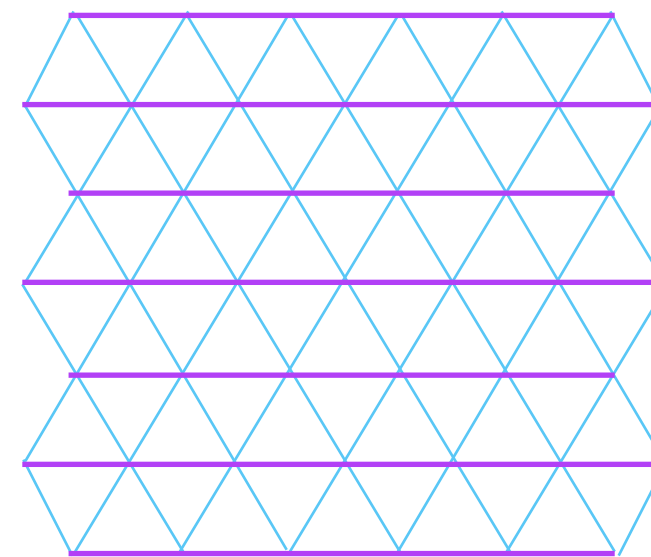

triangular

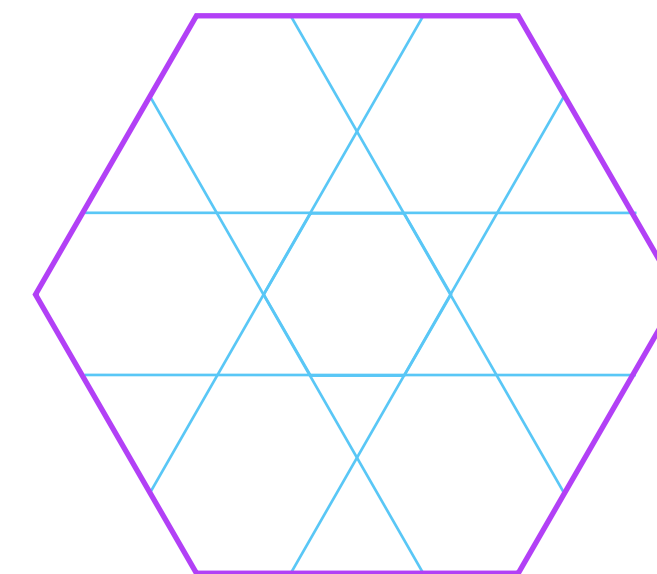

pentagono

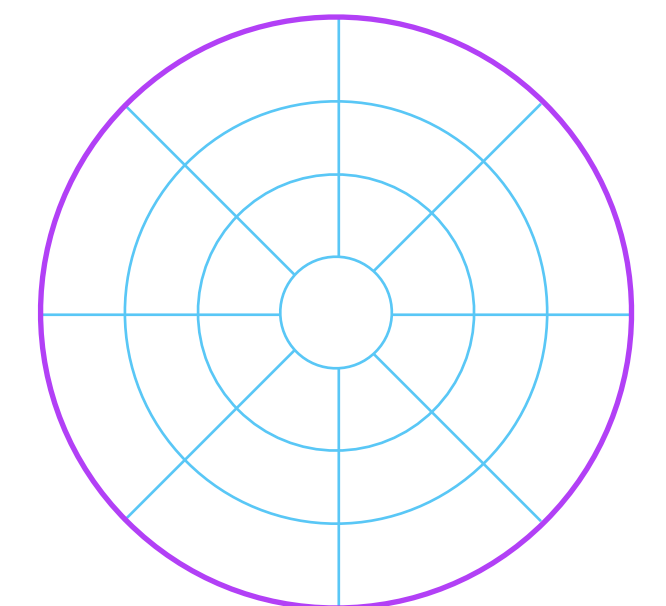

radial

# TIPOS DE GRID

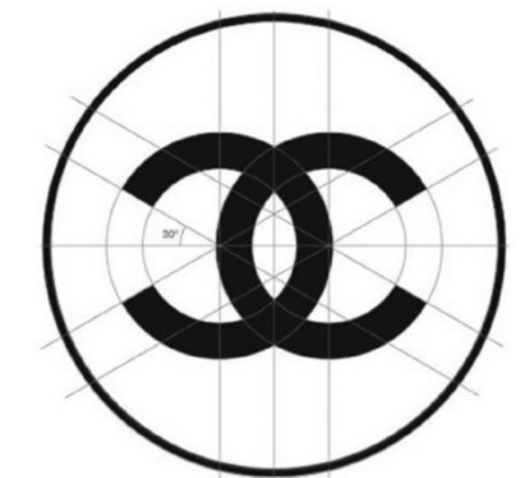
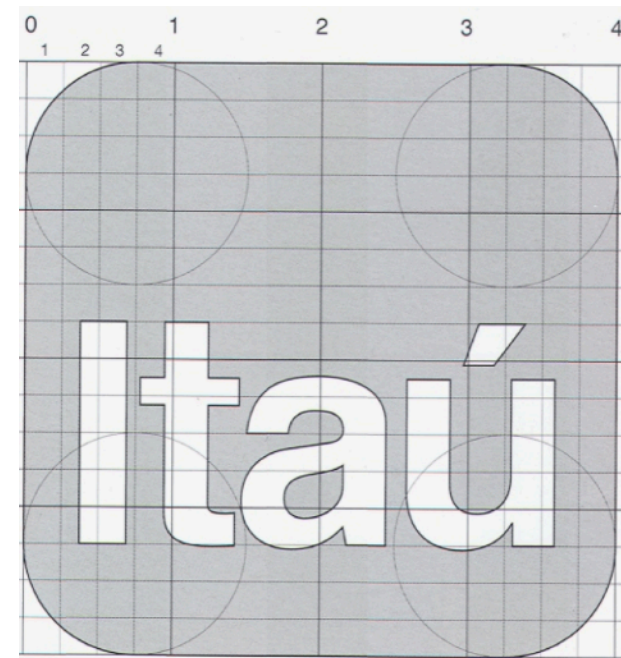
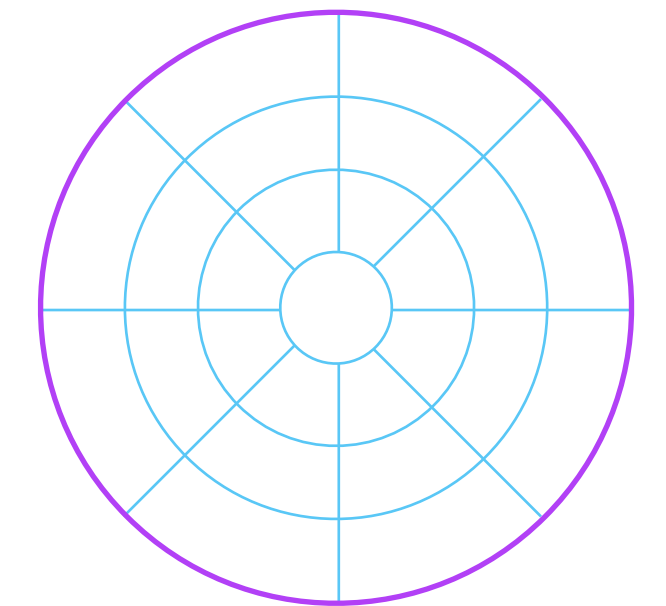
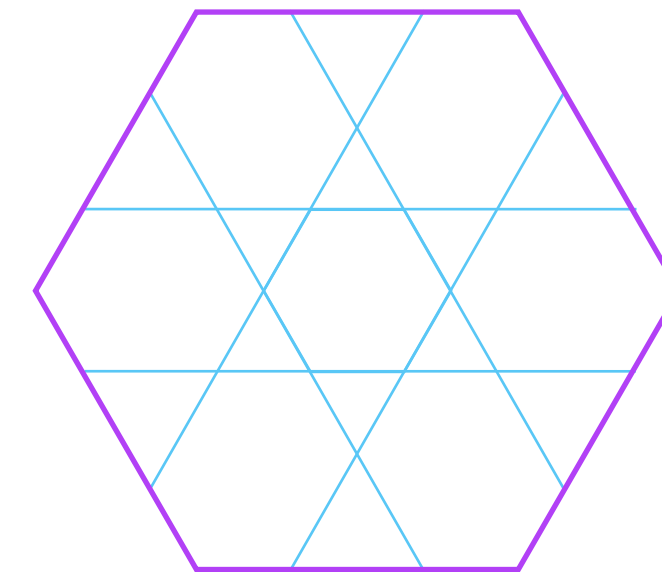
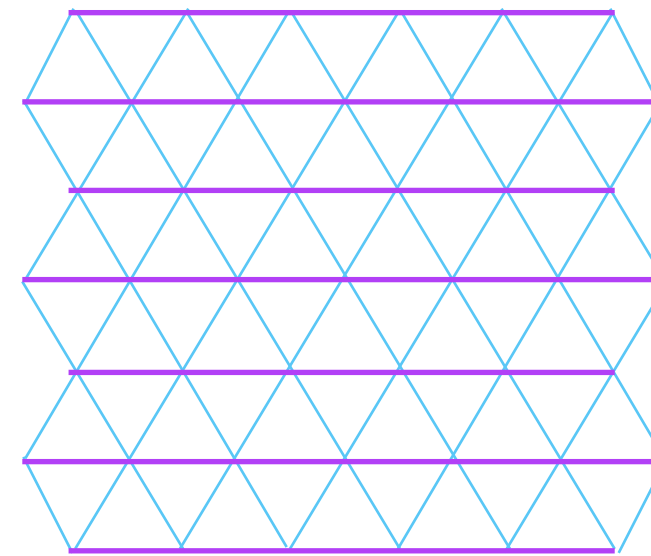
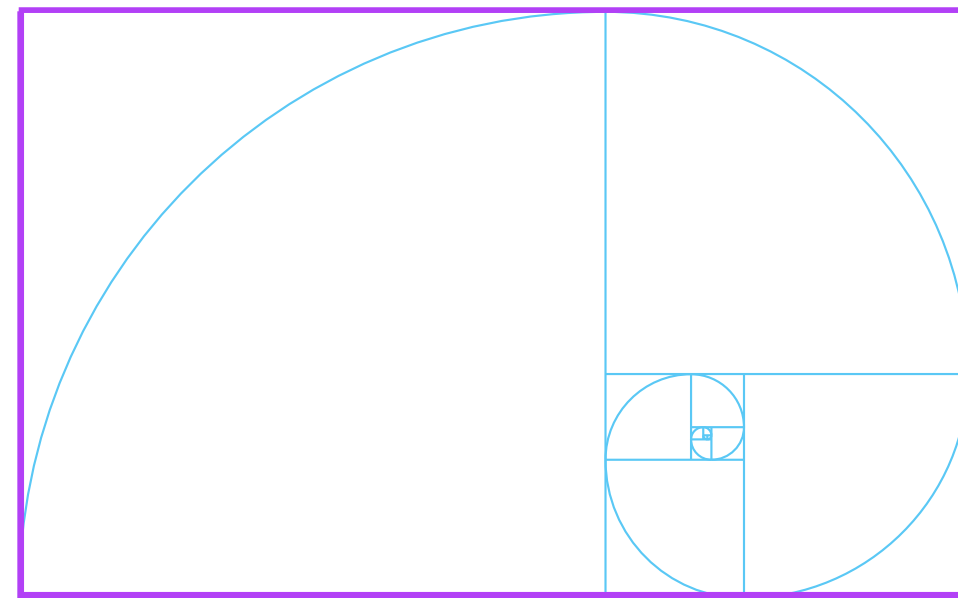
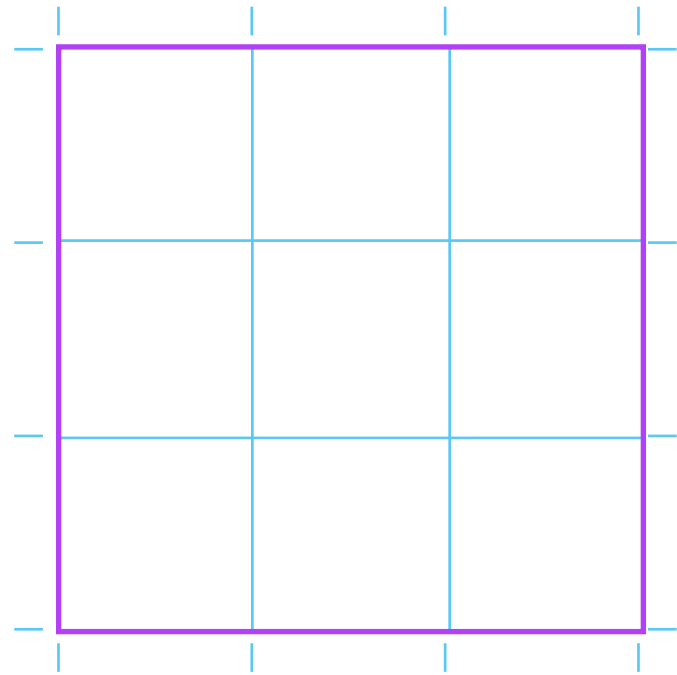

## TIPOS DE GRID

É comum se perder com a variedade de possibilidades nas utilizações de diferentes tipos de grids, mas isso permite que cada profissional possa encontrar uma solução adequada ao projeto e ao próprio estilo pessoal.

@ericlesbatistadesign

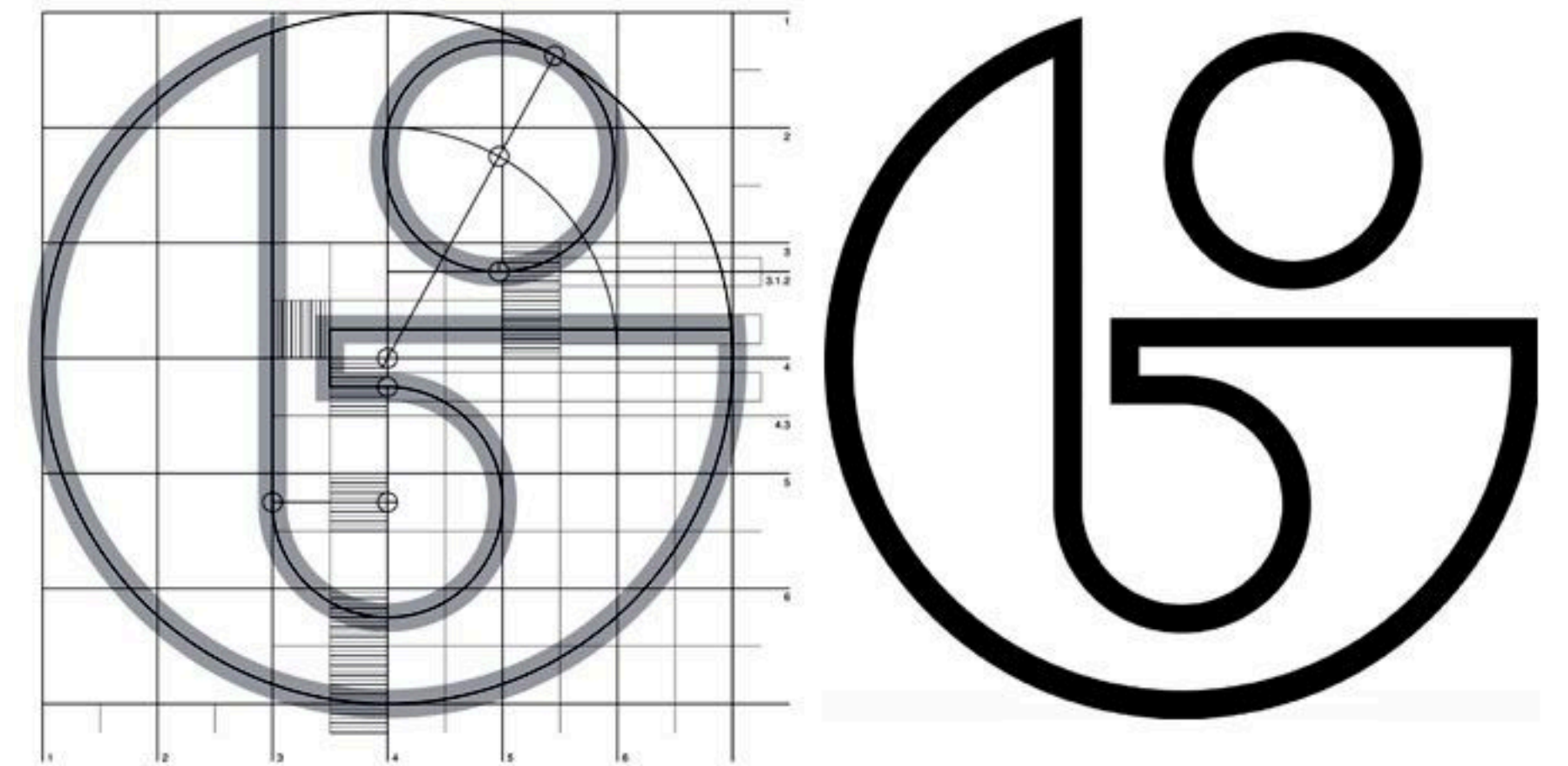

ALOÍSIO MAGALHÃES - ANDRÉ STOLARSKI - FUNDAÇÃO BIENAL (2010)



# TIPOS DE GRID

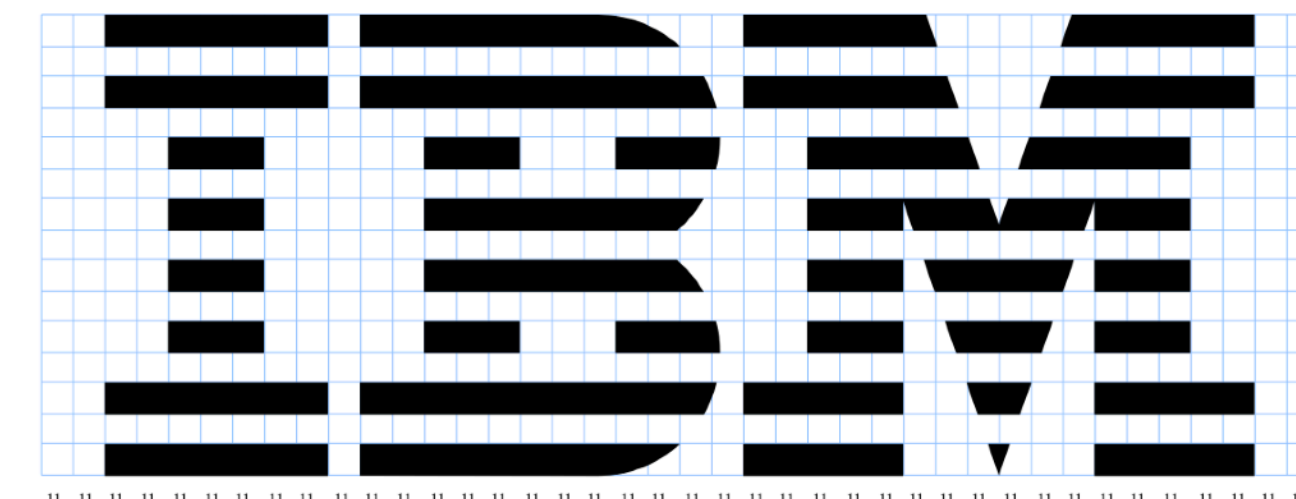
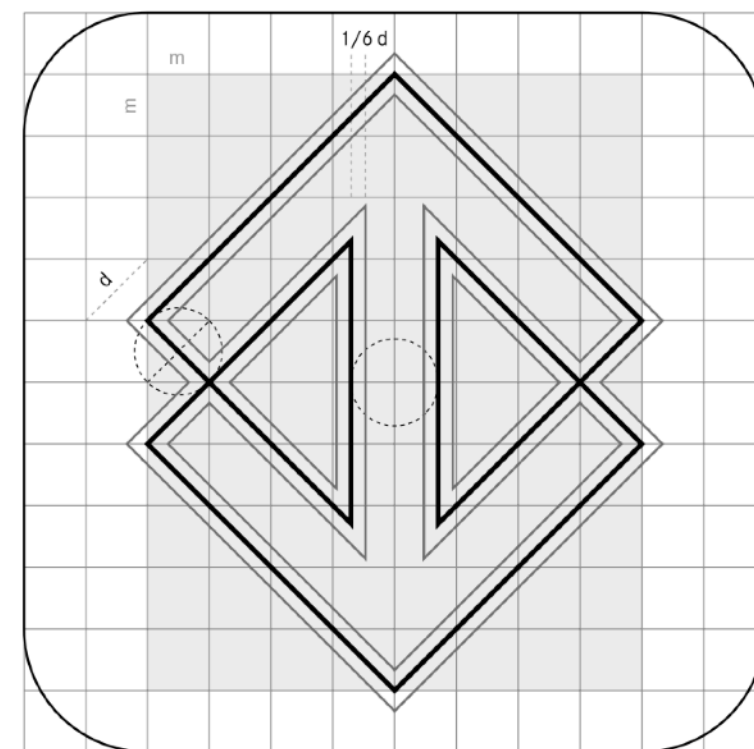
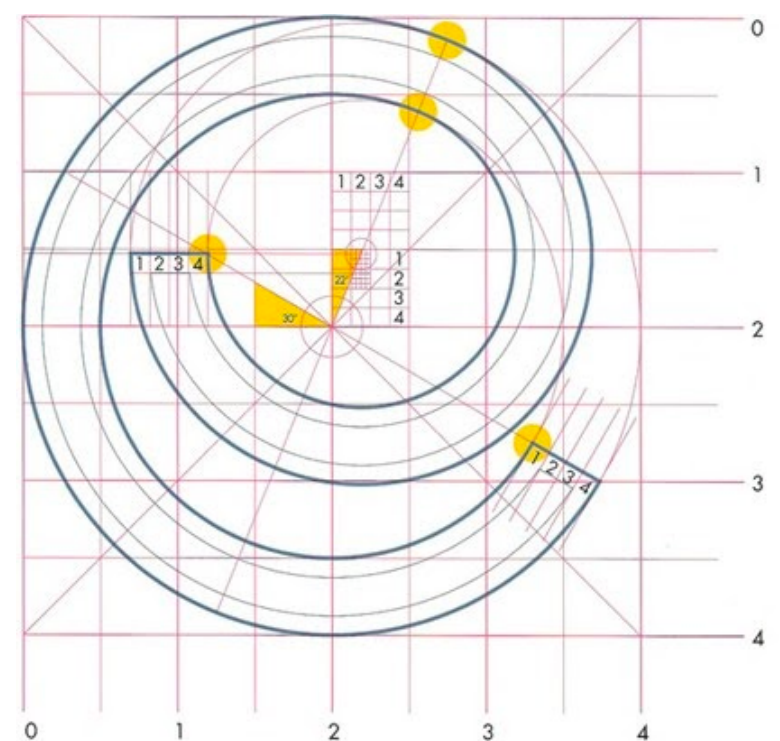
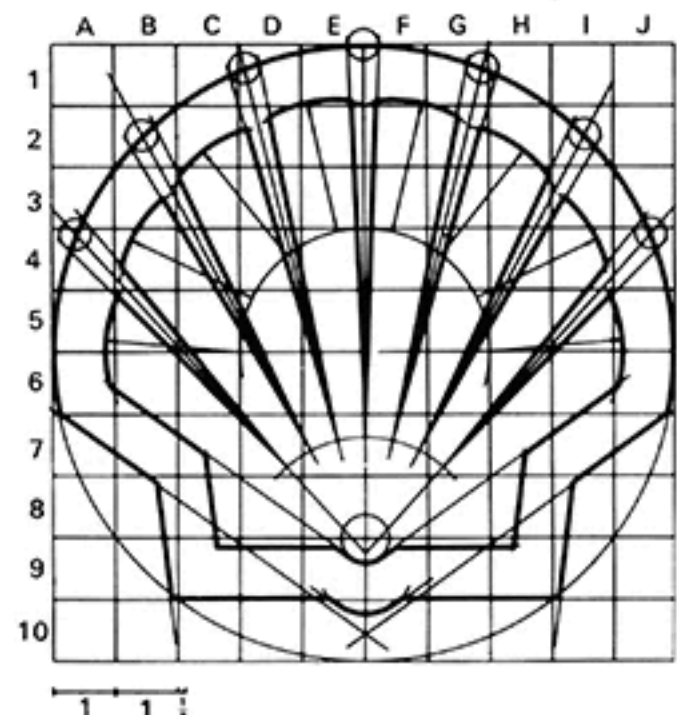

RAYMOND LOEWY - SHELL (1971)

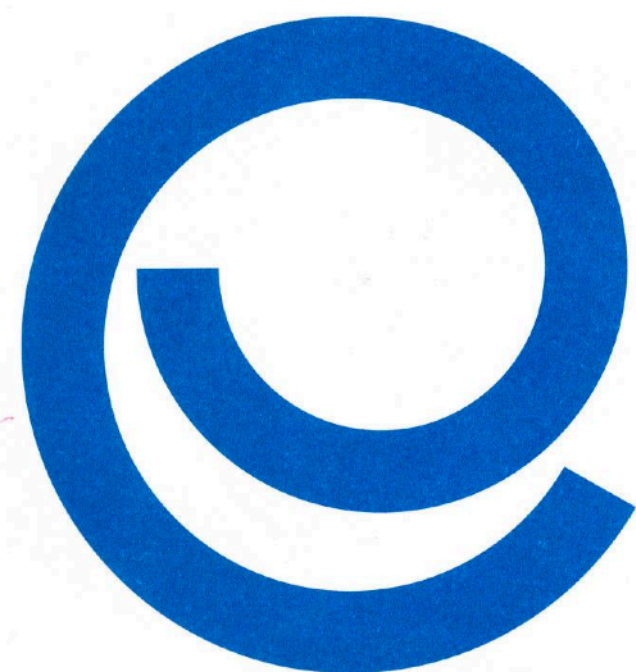

ALEXANDRE WOLLNER - EUCATEX (1967)

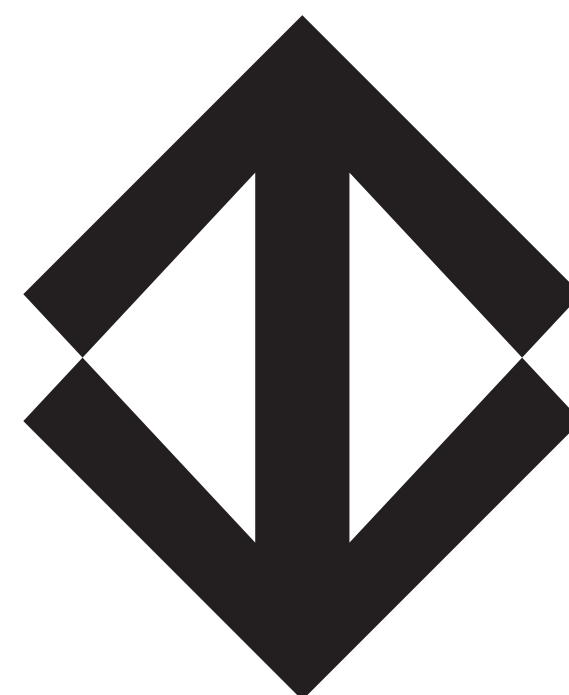

CAUDURO E MARTINO - METRÔ SÃO PAULO (1967)

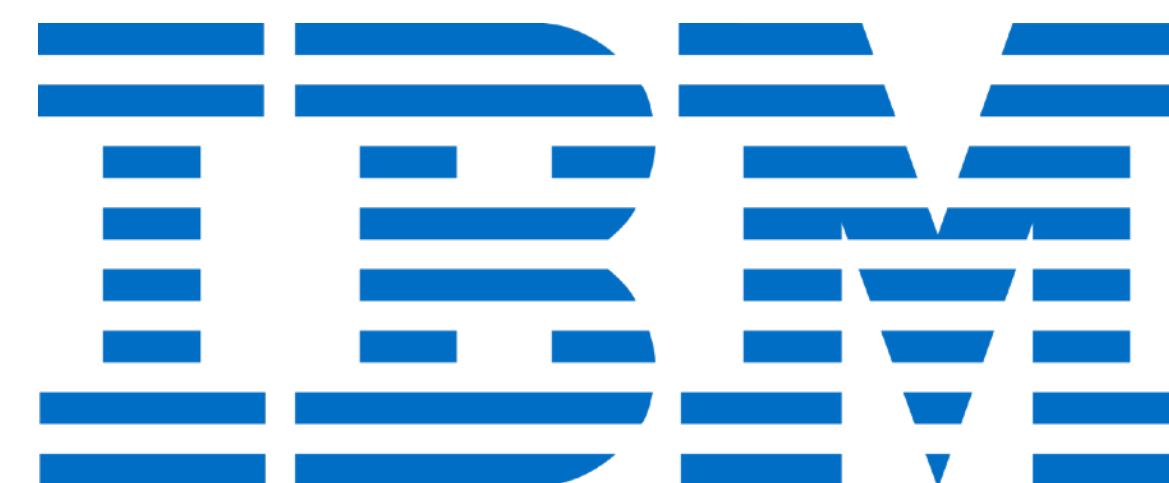

PAUL RAND - IBM (1972)

TIPOS DE GRID

*Campbell's*



**3M**

*Coca-Cola*



# PROPORÇÃO AUREA

Proporção áurea se origina de uma série de números chamada sequência de Fibonacci, que começa com 0 e 1, onde o próximo número é resultado da soma dos dois anteriores, 0,1,1,2,3,5,8...

- Natureza (flores, conchas, via-láctea)
- Pinturas clássicas
- Prédios mundialmente famosos
- Tipografia
- Grids de textos
- Design de sites
- Desenvolvimento de marcas

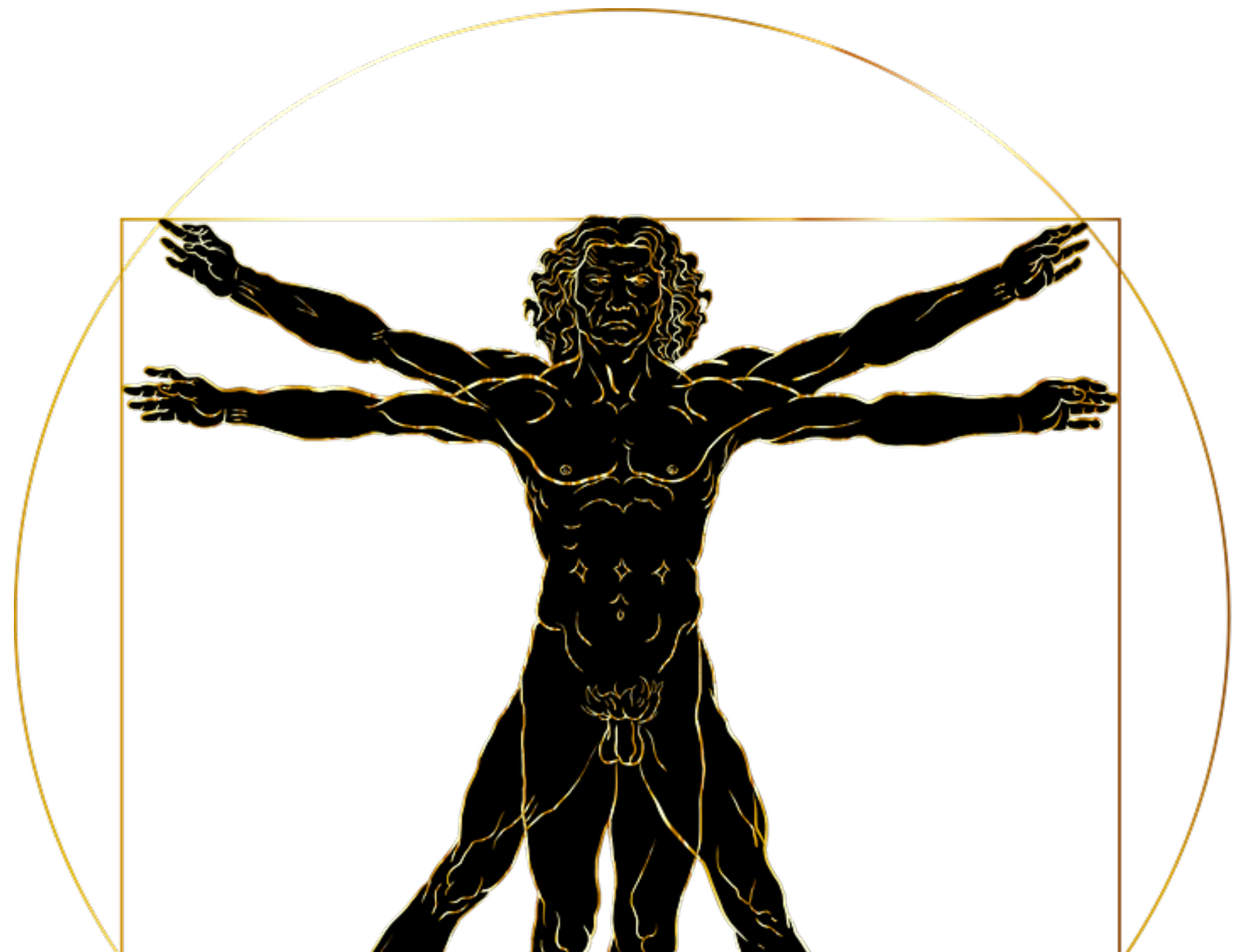

# PROPORÇÃO AUREA

Usar a proporção de ouro no processo de construção da marca, ajuda a criar harmonia em um logo com proporções balanceadas, auxiliando na assimilação e memorização do logo.

A utilização mais comum é da espiral, um jeito fácil de trazer harmonia para a composição. Também podemos utilizar a sequência numérica como direcional de posição ou as formas que se resultam de dentro da espiral.

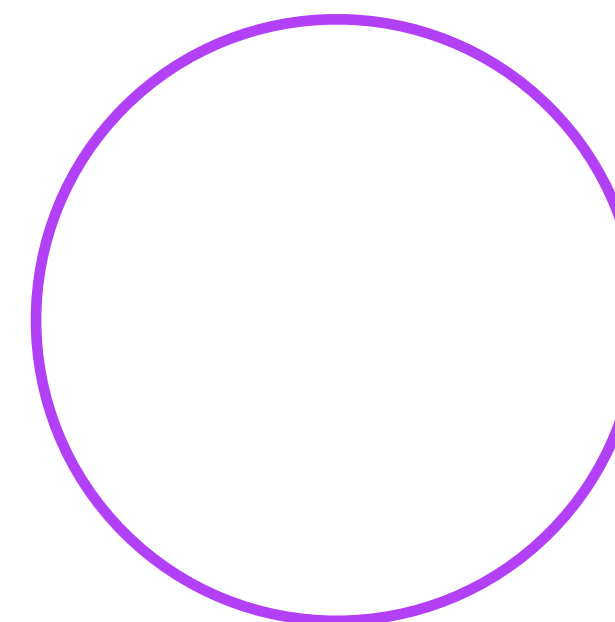
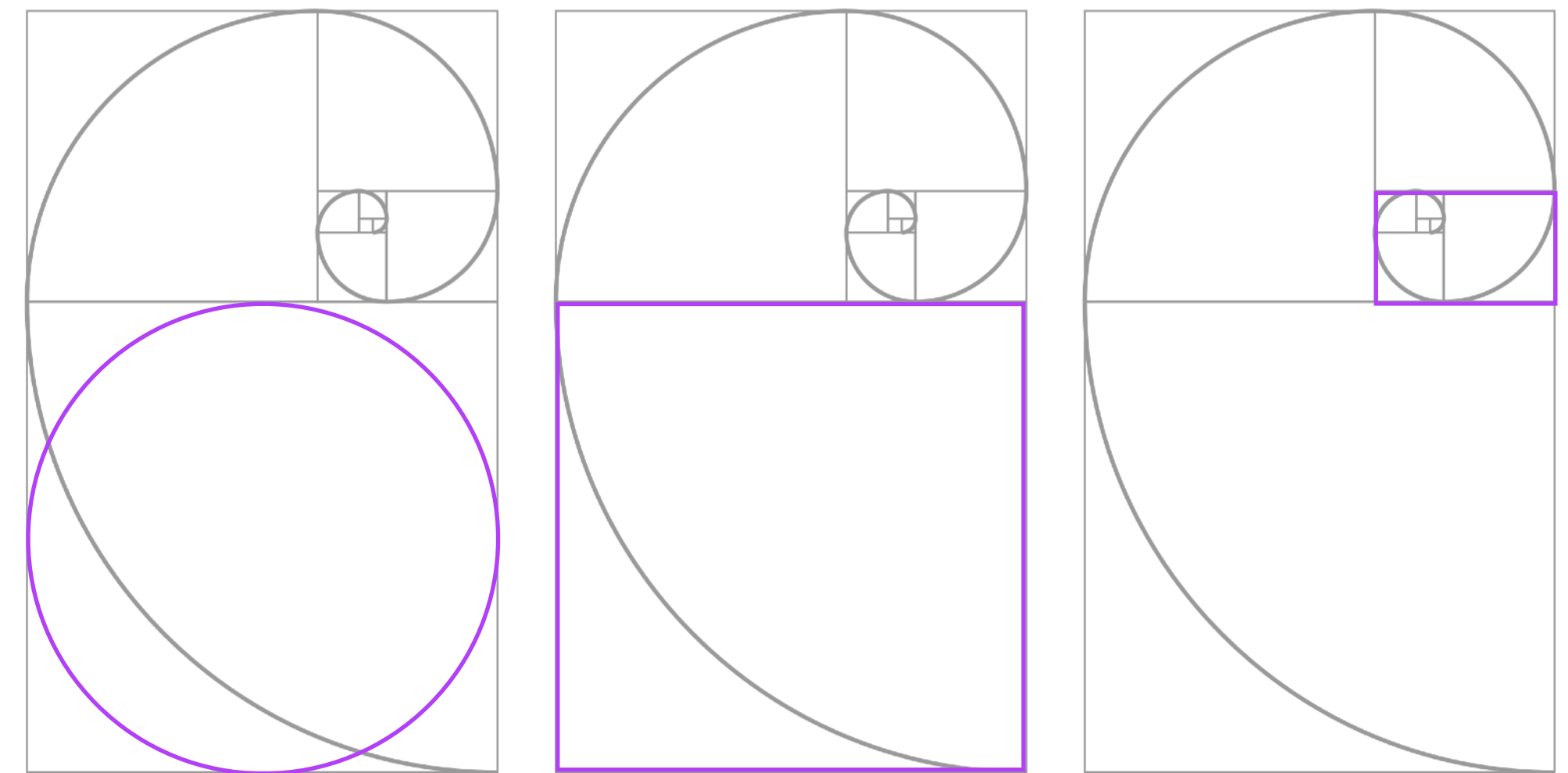



# PROPORÇÃO AUREA

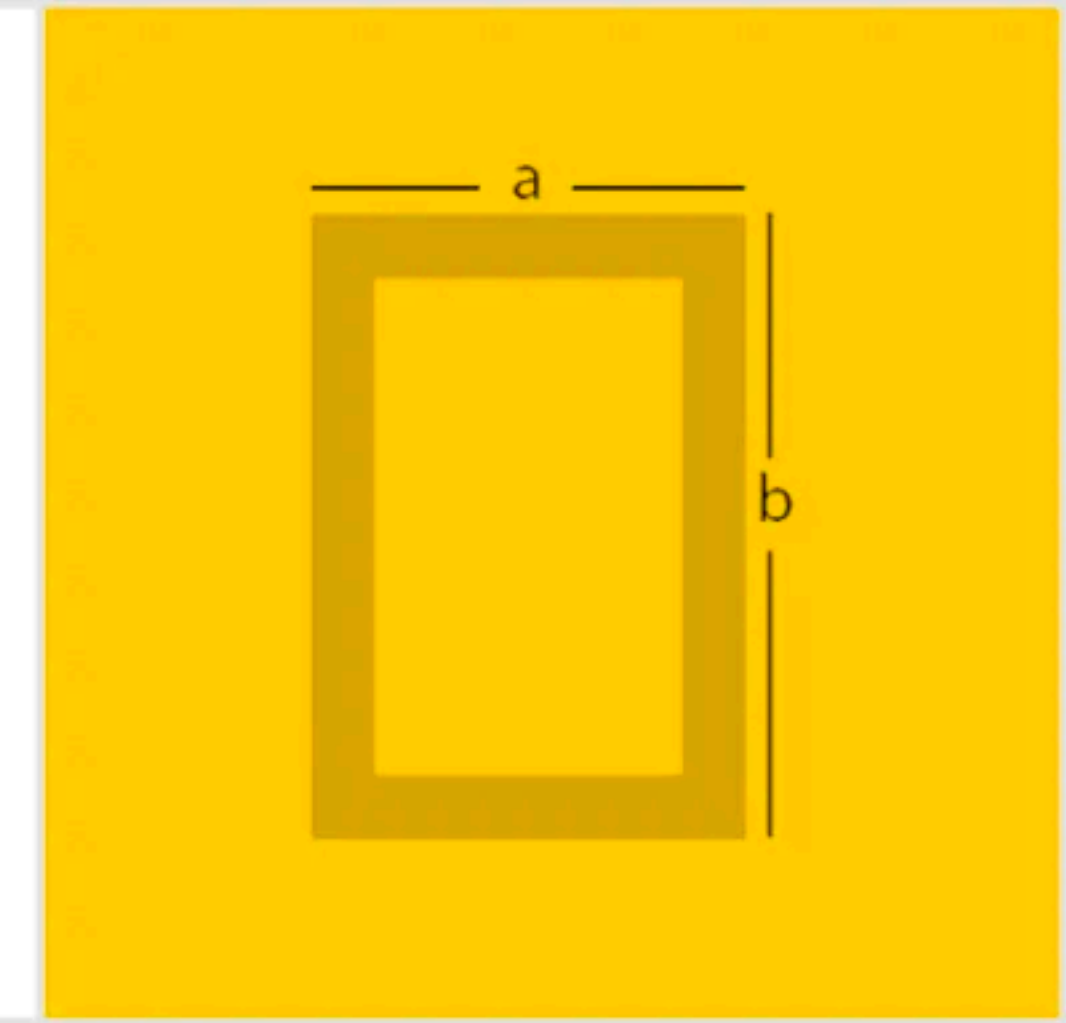
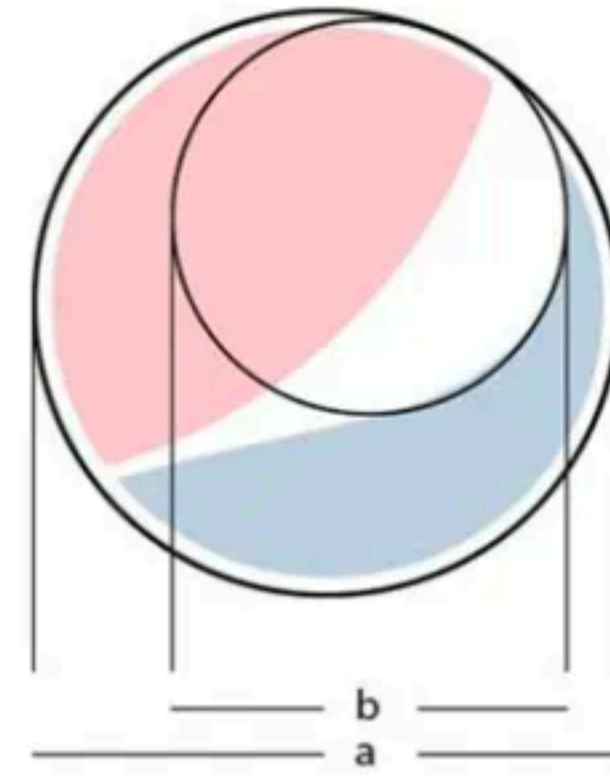
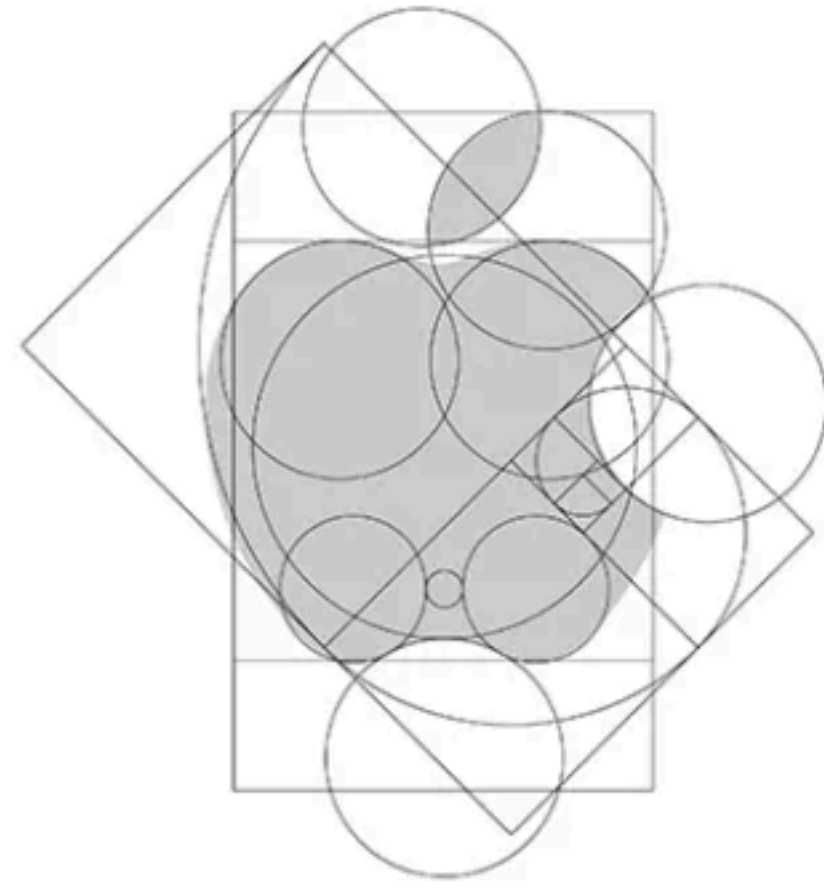
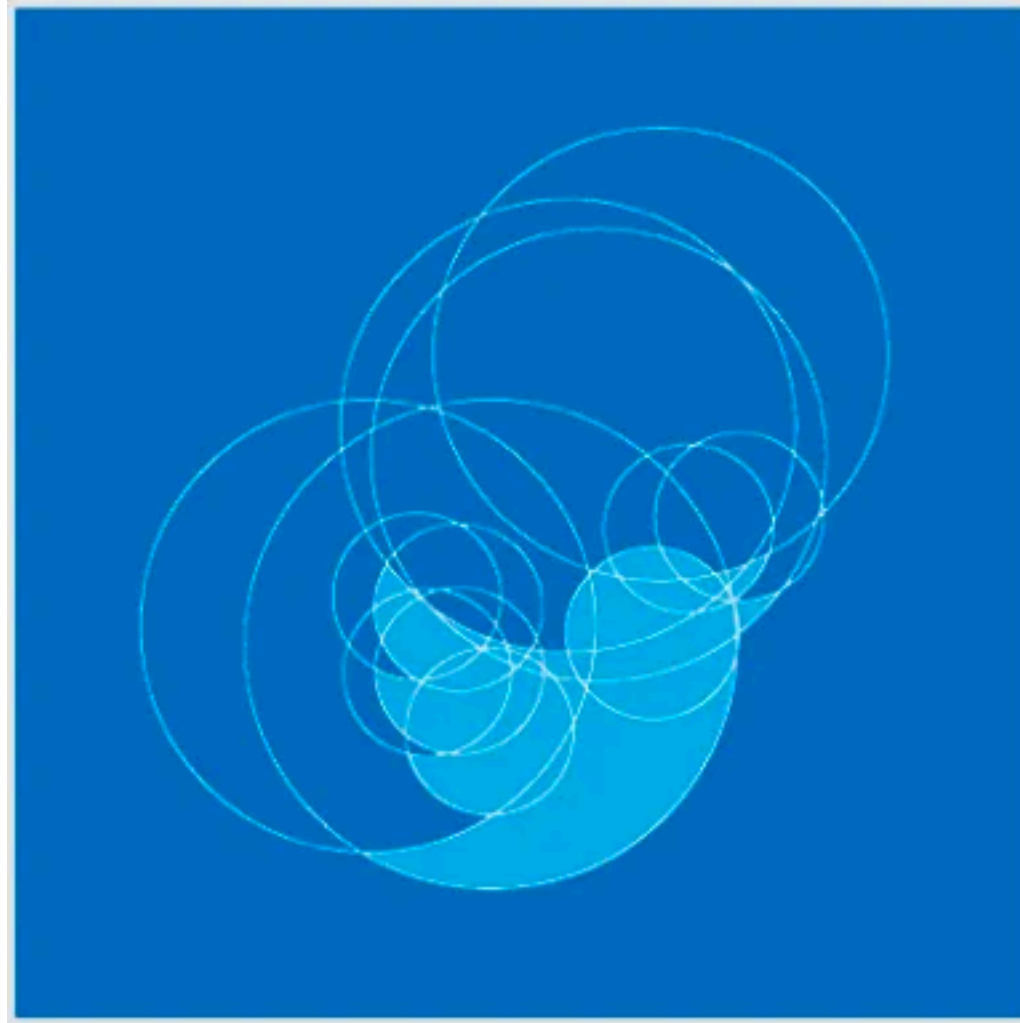

## SIMETRIA PROPOSITAL

The image shows the word "Campbell's" in a red, cursive script font. A second, identical word is positioned directly below it, rendered in a light cyan color. This cyan word is slightly offset to the left and right, creating a layered, symmetrical effect. The registration mark (®) is visible at the end of the word.

Na simetria proposital, utilizamos uma parte da própria composição como base para uma divisão harmonica dos elementos.

**SIMETRIA PROPOSITAL**



# SIMETRIA PROPOSITAL

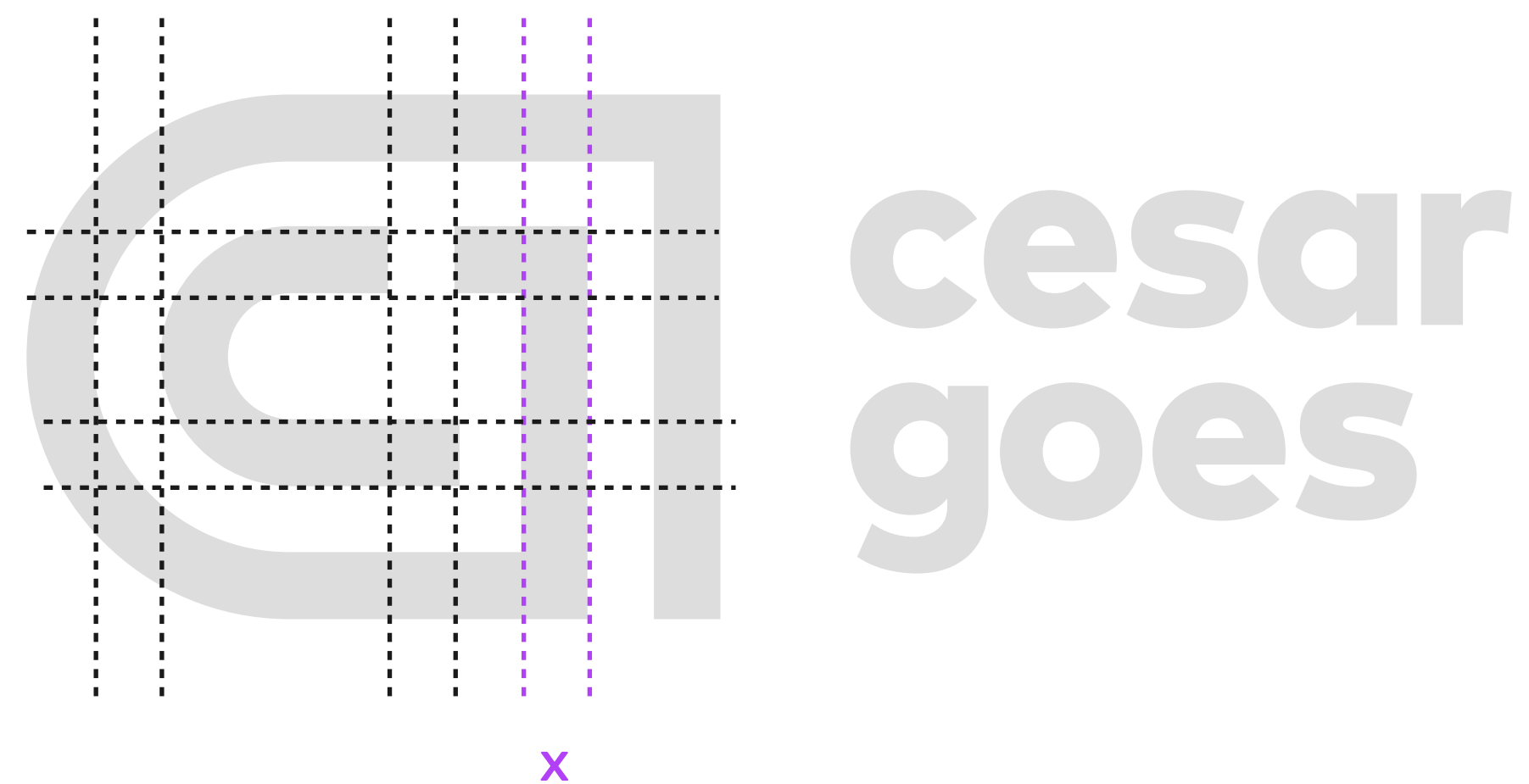

# SIMETRIA PROPOSITAL

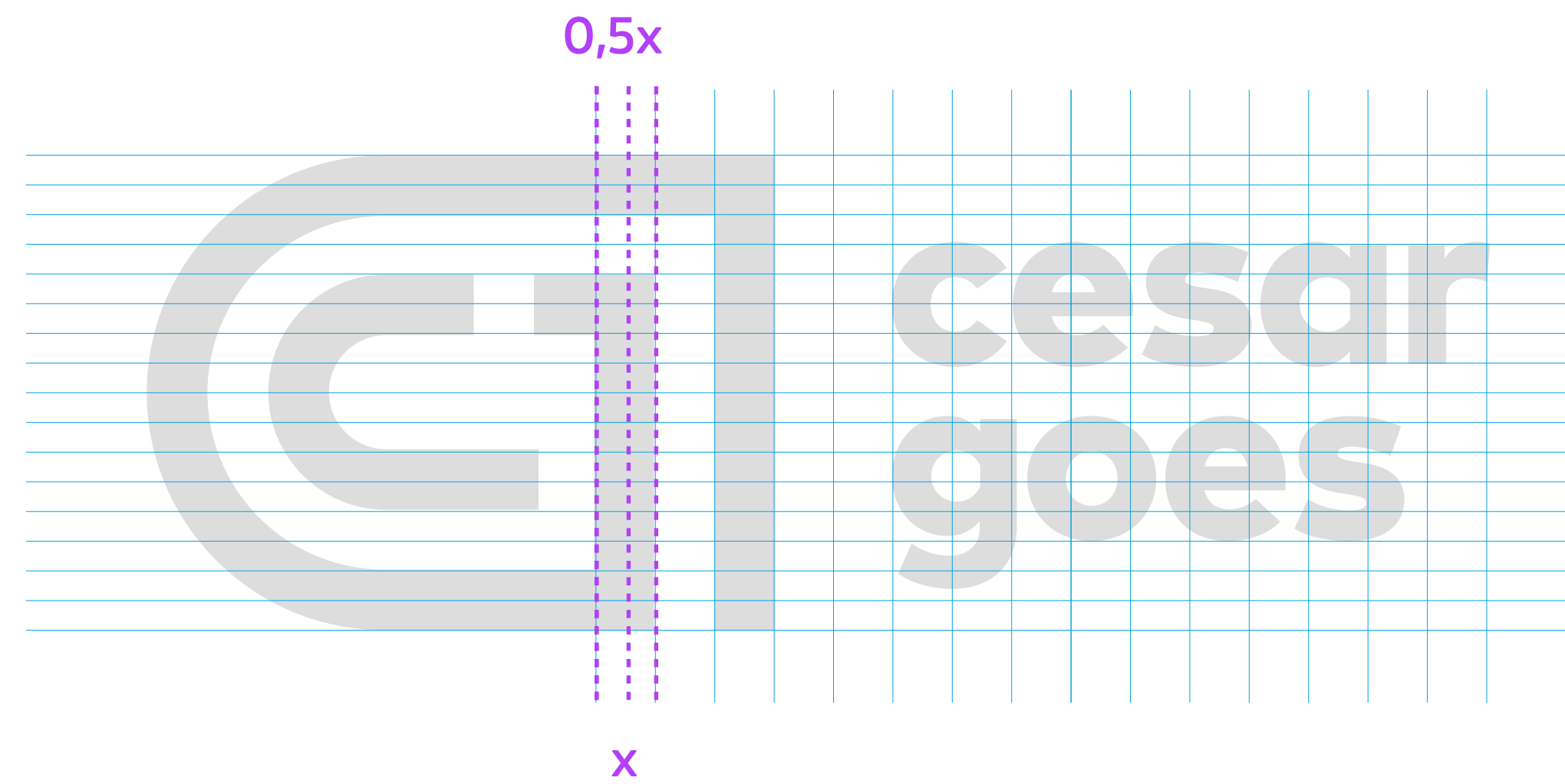

# SIMETRIA PROPOSITAL

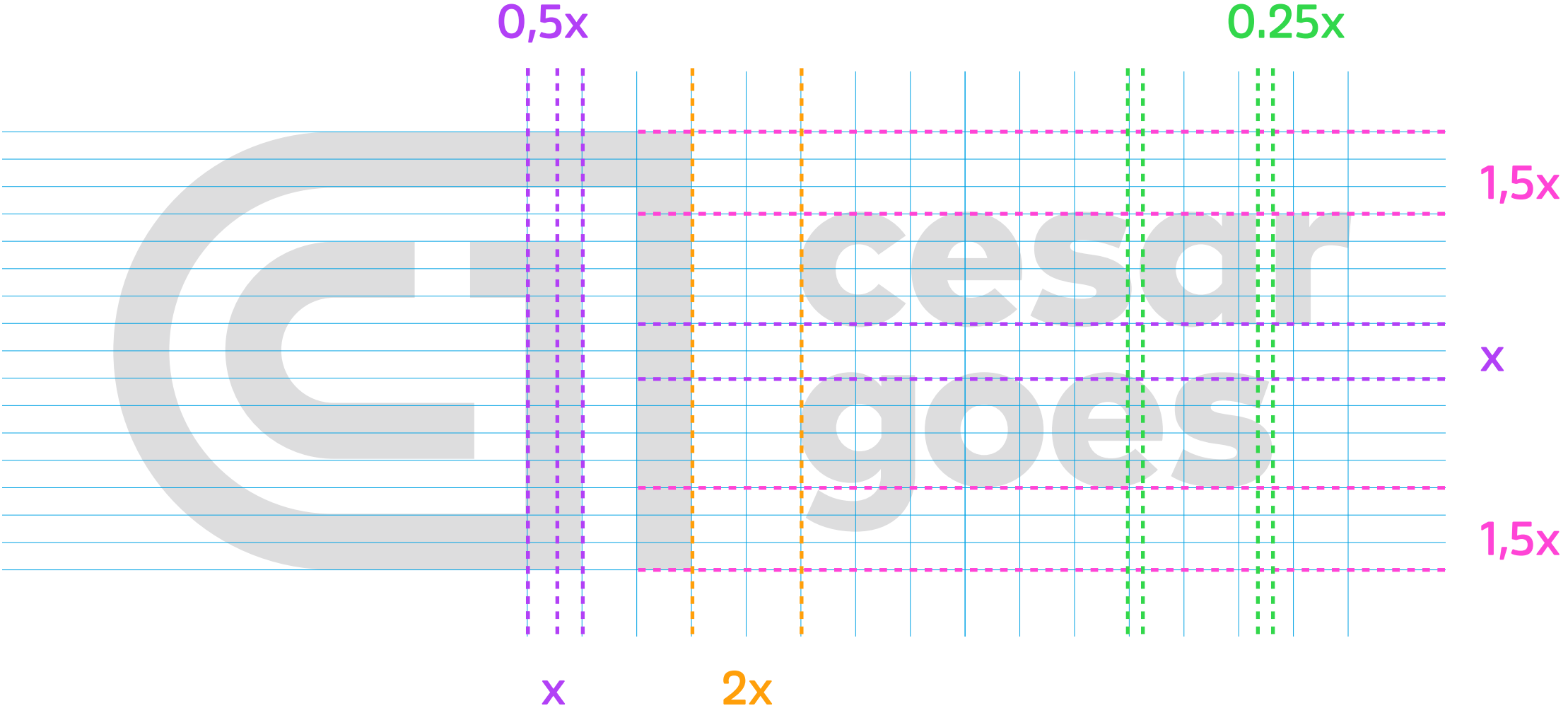

## COMO CONSTRUIR SEU GRID

Estabelecer o módulo padrão é o passo inicial para a definição das corretas relações entre os componentes do símbolo e, a partir desta definição, estruturar todo o comportamento das expressões visuais da marca.

A base do sistema modular é o quadrado. Através dele podemos estabelecer um módulo padrão e assim criar uma estrutura para a construção de todos os diagramas da identidade.

Alexandre Wollner: Design Visual 50 Anos

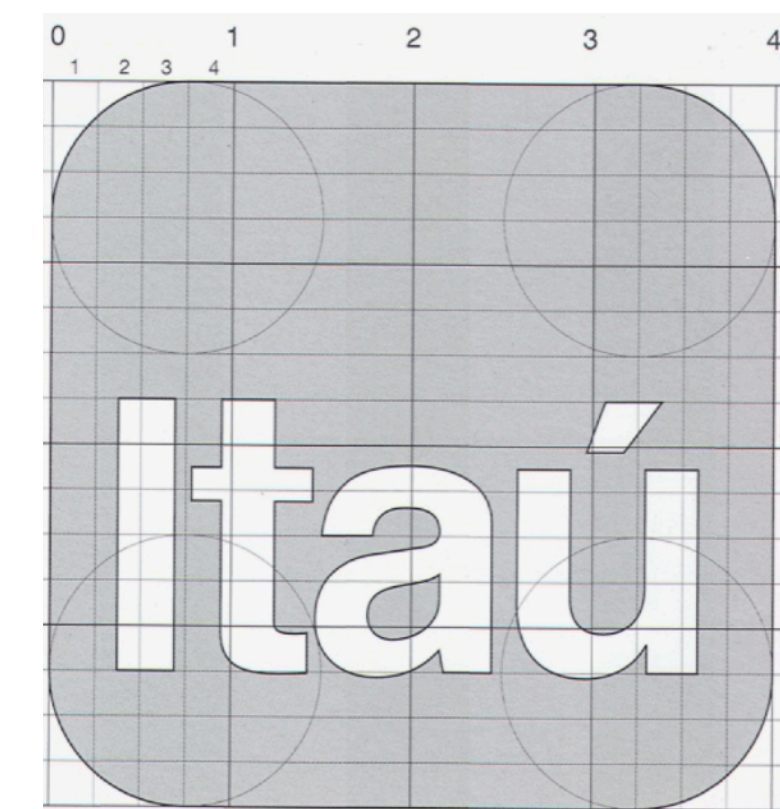
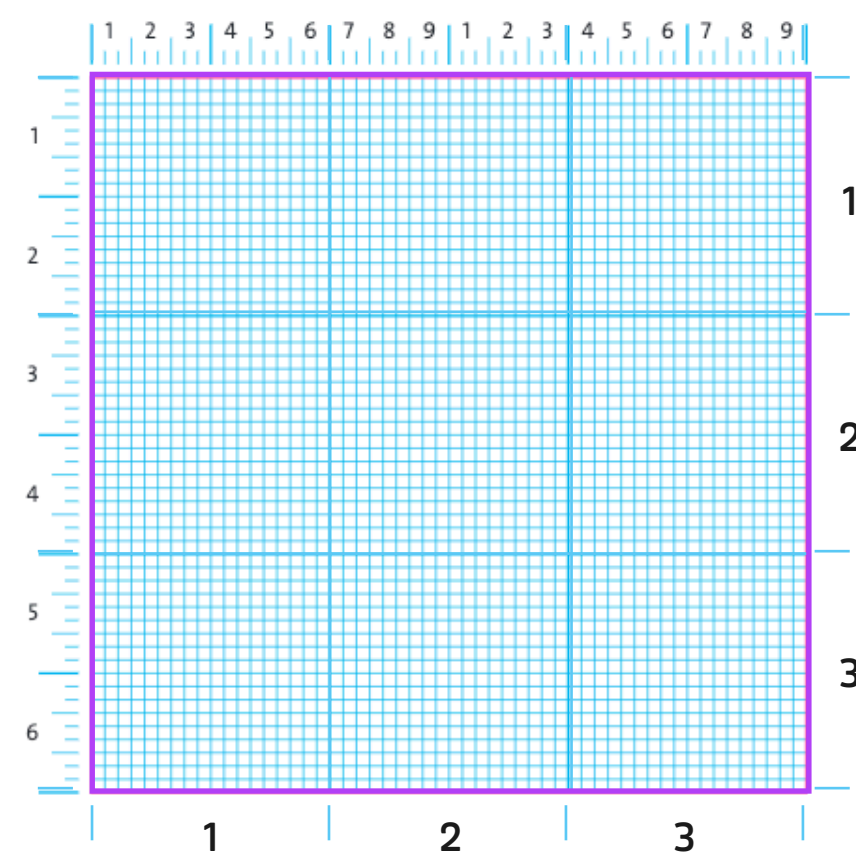
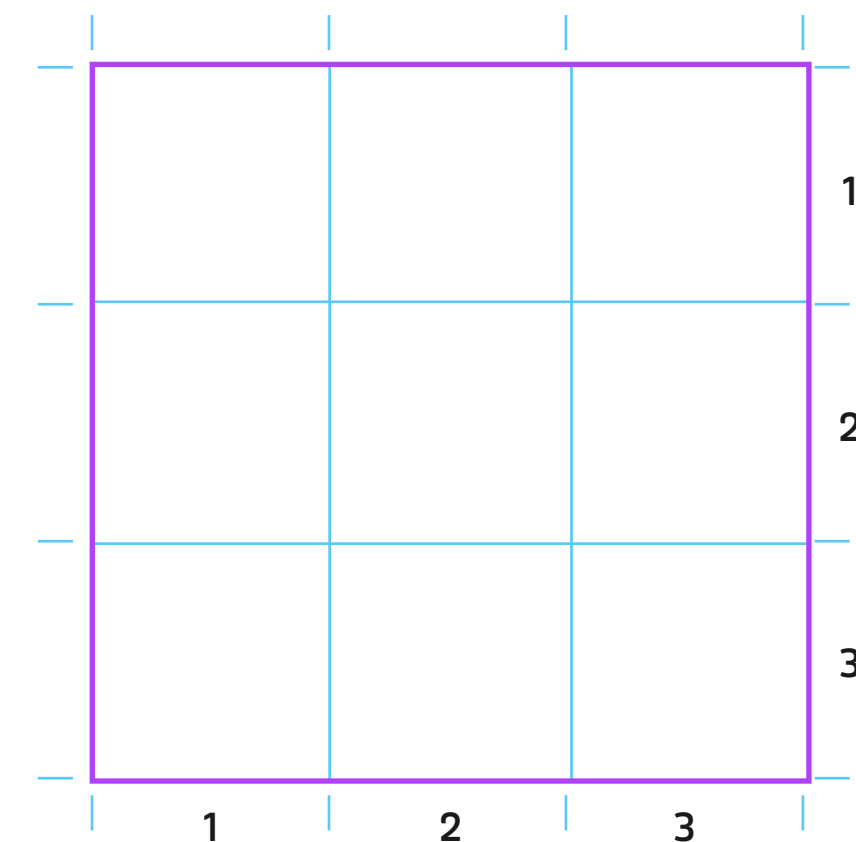

## COMO CONSTRUIR SEU GRID





# CURADORIA DO CONHECIMENTO

→ a identidade visual da  
fundação bienal são paulo  
premissas de complementação  
da identidade visual da instituição

conheça

→ gridzzly

site onde você pode personalizar  
diversos tipos de grid, além de escolher  
a espessura e a cor. Depois é só salvar  
em pdf ou imprimir direto.

yeah!

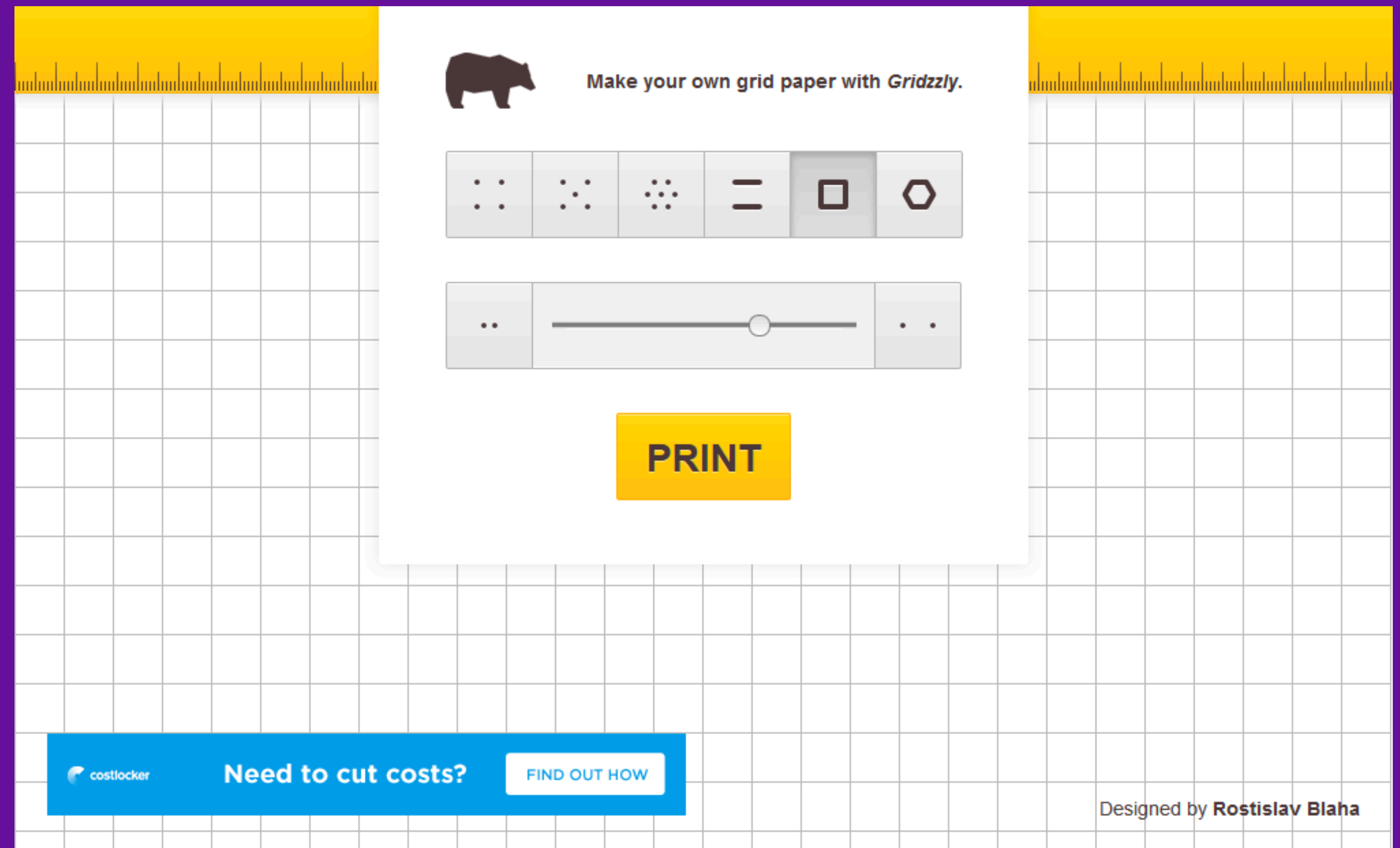

# CURADORIA DO CONHECIMENTO

→ sistema de grids em 20 marcas famosas  
malha construtiva de 20 marcas

conheça

→ um estudo sobre a nova marca da Xiaomi  
mathematic dude!

yeah!

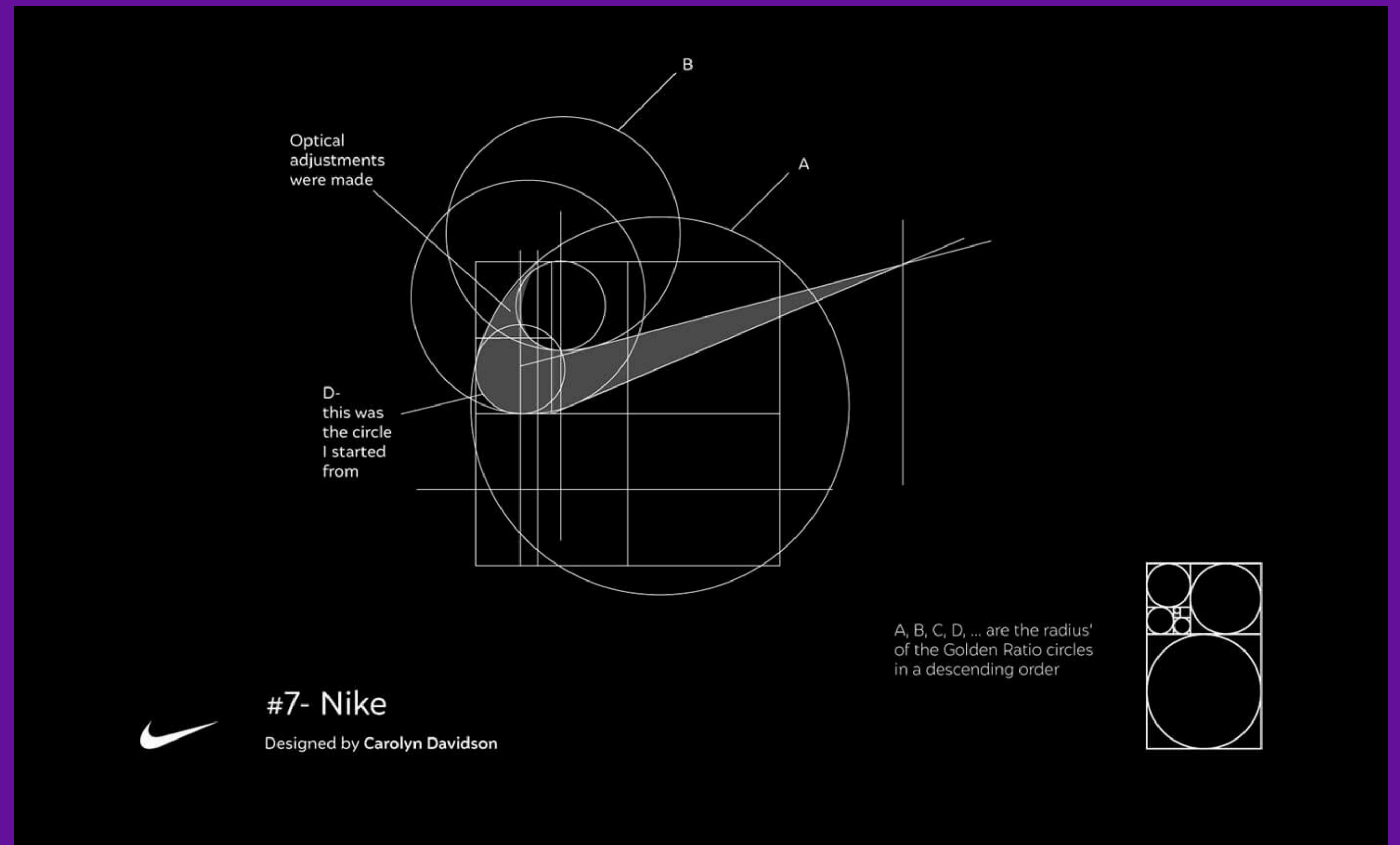

branding &  
identidade visual

—  
**OBRIGADO**